

SR-400 CYCLONE TO SR-400 CYCLONE II UPGRADE

WRITTEN BY WDØGOF

This upgrade assumes you are starting with a first production run Cyclone. As you proceed you may find some of the modifications have already been installed. This will affirm that your rig is a later production run. It is of upmost importance that you should have the SR-400 Cyclone schematic # 155-000459 and the SR-400 Cyclone II schematic # 155-000459F on hand before you start. **(Not included in this document)** Study both schematics and locate all the involved components **on the schematics** and **in the chassis** before you start.

IT IS IMPERATIVE THAT YOUR 400 BE FULLY FUNCTIONAL AND PERFORMING AT LEAST VERY CLOSE TO SPEC BEFORE YOU START THE MODIFICATION. YOU HAVE BEEN WARNED, IF NOT HEADED YOU WILL MOST ASSUREDLY BE BESIEGED BY MURPHY'S LAW AND O'MALLEY'S AXIOM. THE IMPORTANCE OF THIS CANNOT BE OVERSTRESSED.....

This is an extensive modification. You must have better than average skills in tracing circuits from the schematic to the chassis. Also, better than average skills with hand tools and soldering and de-soldering are required. Get all your parts, tools and documents together before you start. When removing parts leave your side-cutters in your tool box. De-solder each connection, clean holes and pins to accommodate proper wrap and crimp of new parts. Once again Murphy will get you if you don't.

Thanks and credit to Bob, AB1MN for his assistance in this project. He took the draft procedure and attacked his 400. He provided many improvements and corrections. Also to Jim K9AXN, who knows the 400 forwards and backwards and contributed significantly to the technical accuracy.

Comments from AB1MN:

I would suggest adding a cautionary note about overheating the lugs on L15 and L16 as the plastic melts rather easily. This is particularly challenging when removing components as it is a bit of a chore to get the wires free of the lugs (they either go through a hole in the lug and are wrapped around the lug or just wrapped around the lug. I had the misfortune of one of the lugs breaking off on L16, but fortunately, I was able to remove the coil from the can and connect the wire to one of the formerly unused lugs. This did slow me down a bit, however.

Tools that I used: small needle nose pliers, hemostat, dental picks of different shapes to help free up component leads, small wire cutters, vacuum solder sucker, small screwdriver (also to free up leads), solder gun (although a medium wattage iron 40-60w would probably be better).

I tackled the filter rewiring today. This is not for the faint of heart. I started about 9am and just finished everything tonight almost midnight

I did not need to add the wire shown between R36 and the junction of R175 and R171 those points were already connected. However, I overlooked this wire when I did my initial rework (even though I later found it wasn't needed anyway).

WDØGOF 3/6/2014

BILL OF MATERIALS

(ref designators reflect assignments on the F level schematic)

RESISTORS	CAPACITORS	MISC.
2.7k ½ watt, R8	47pf 500v silver mica, C220 *	8.2uh choke, L46
4.7k ½ watt, R66	100pf 500v silver mica, C221	
5.6k ½ watt, R67	2 ea 135pf 500v silver mica, C217, C148	1N456 diode, CR29
470k ½ watt, R177	2 ea 180pf 500v silver mica, C223, C224	
150k ½ watt, R178	22pf 500v silver mica C110	
120 ohm ½ watt, R180	.005uf 500v ceramic disc, C60	
680 ohm ½ watt, R182	33pf 500v silver mica, C48	
22k ½ watt, R168	47pf 500v silver mica, C16	
10k ½ watt, R169	310pf 500v silver mica, C63	
100K ½ watt, R170	50pf 500v silver mica, C214	
	.01uf 100v ceramic disc, C228	
	5uf 35v electrolytic, C218	

*This value may be reduced to improve drive in CW mode. If it is reduced the spurs and harmonics in SSB modes should be checked. C220 is located in the grid ckt of V2. It was removed in the 400A.

SR-400 CYCLONE TO SR-400 CYCLONE II UPGRADE cont.

Ok: you have filled the bill of materials; your 400 functions and at least comes close to spec operation; you have diligently studied the procedure and the schematics; RIGHT.... Let's get started.

- A. Replace R8 4.7K with a 3.3K. (In parallel with L11)
- B. Add a 47pf (C220) capacitor from V2 pin 2 to ground. (Value is selected for CW drive level. Reduce to increase drive.)
- C. Add a 100pf (C221) capacitor in parallel with C40. (Pin 3 of V3A)
- D. Change R66 (1.5K) to 2.7K. (S1E lug 4 & 5)
- E. Change R67 (2.7K) to 4.7K. (S1E lug 3)
- F. Replace C148 (270pf) with two 135pf capacitors in parallel. (PA band selector switch S1K lug 10)
- G. Replace R118 (2.2K) with 5.6K. (Pin 8 of V8B)
- H. Replace C110 (22pf) with 180pf. (cathode ckt of V4B)
- I. Add a 22pf capacitor in parallel with an 82uh choke between the tie point of C110 / C111 and pin 7 of V2B.

H & I detail

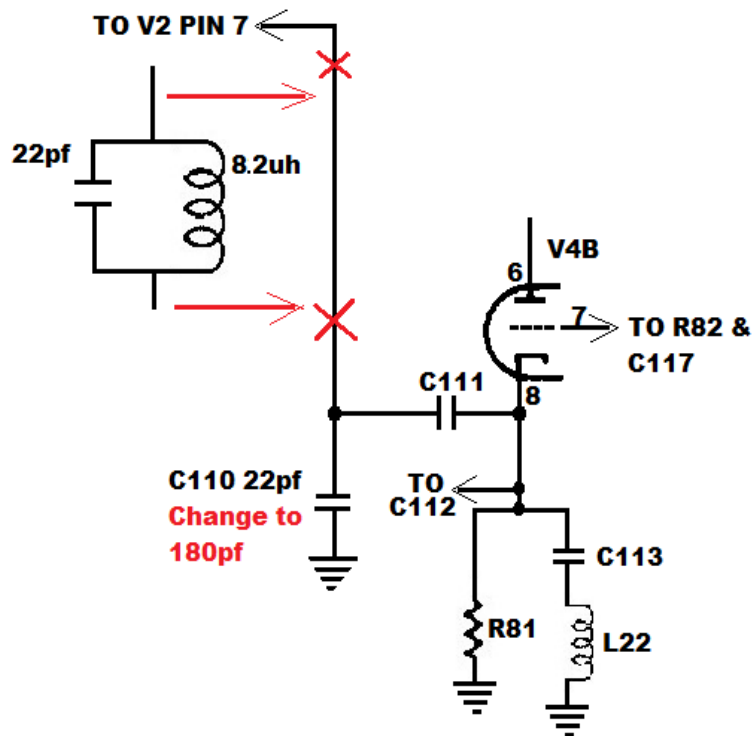

SR-400 CYCLONE TO SR-400 CYCLONE II UPGRADE cont.

- J. Add a 180pf capacitor from pin 7 of V2B to gnd.
- K. Add a 1N456 diode from the cathode of CR15 to ground, with the anode to the cathode of CR15 and the cathode to ground. This part may be salvaged from stripped parts see page 5.
- L. Disconnect C8 (Pin 7 of V7A) from pin 3 of T3 and connect it to ground.
- M. Add a .005 capacitor from pin 3 of T3 to ground.
- O. Add 100k resistor from V1 pin 6 to gnd
- P. Change C48 (22pf) to 33pf. (pin 2 V4)
- Q. Change C16 (22pf) to 47pf. (pin 1 V4)

Ok the easy part is done.

MICROPHONE AMP MOD.

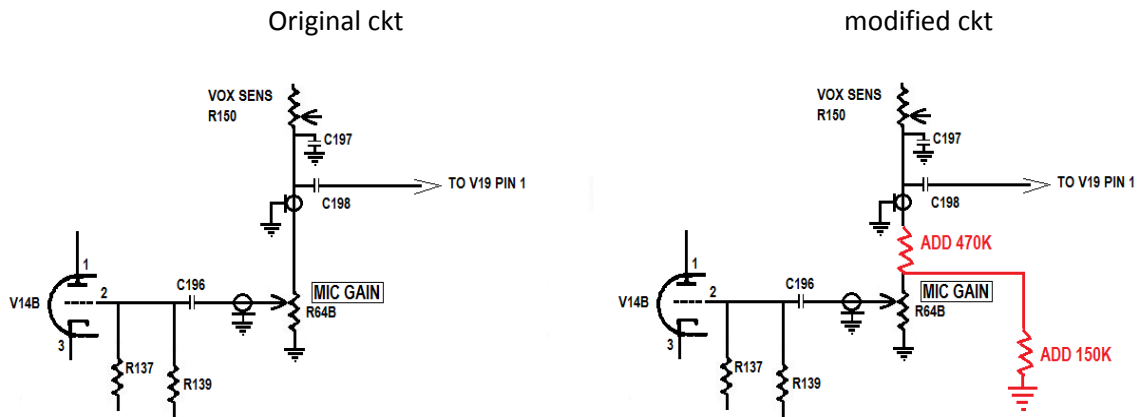

AUDIO OUTPUT/RELAY CONTROL MOD.

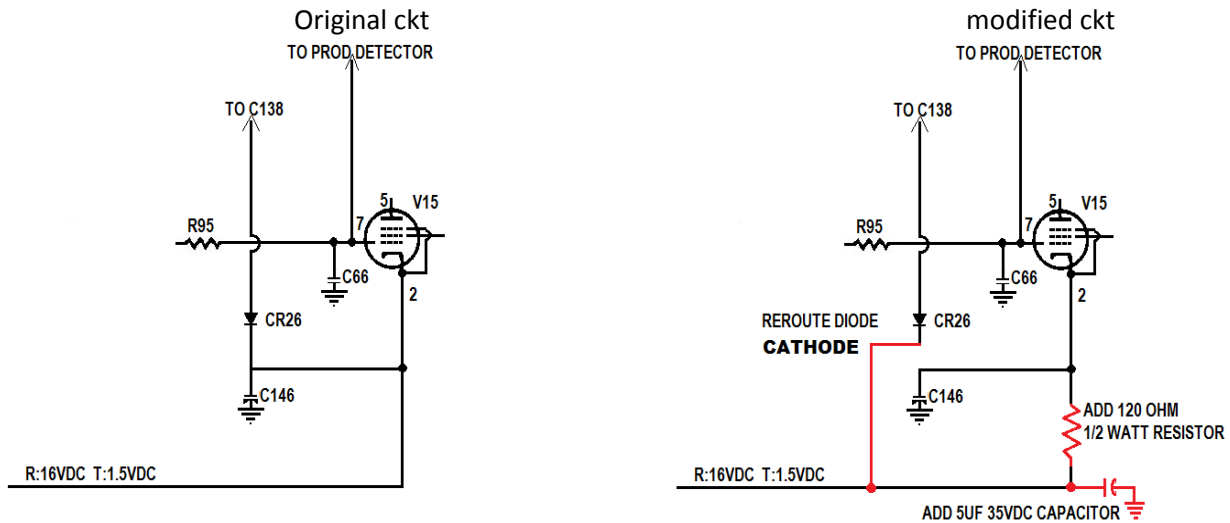

FL1 & NOTCH FILTER MODIFICATION cont.

Add and connect components as marked in **RED**.

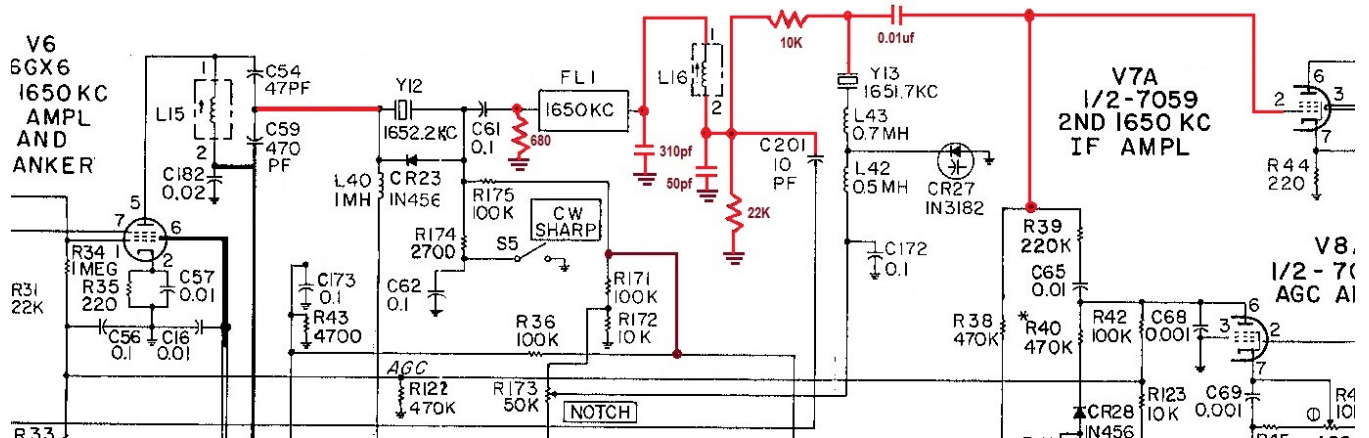

Note: There is a conflict with the F level schematic and prior production runs. The schematic shows the 10K resistor R169 connected to pin 1 of L16. Some production runs it is connected to pin 2 as indicated above. The jury is still out on this one. There was an internal change in FL1. They did not make any change to the part # of the filters after the change. The original filter works best with the 10K resistor connected to pin 1. Later production run filters work better with the 10K connected to pin 2. All I can offer at this time is try the connection to pin 2 first. If the receiver is weak try pin 1.

C27 INSTALLATION AND LOCATION

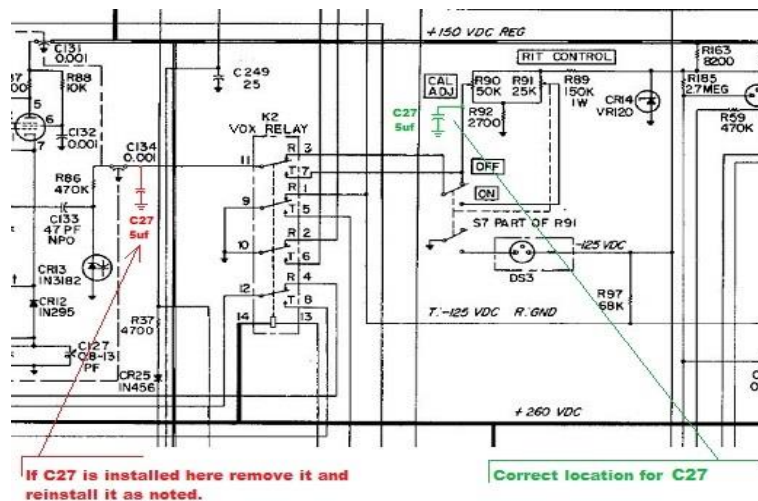

The existence of and placement of C27 although not a part of the upgrade should be noted. There is a chirp and or FM problem in all the SR series radios. C27 eliminates the problem unfortunately it was installed in the wrong place. NOTE the drawing above.

Ok, you are finished. Theoretically, if your 400 was working before you started, when you turn it on you will have a super functioning rig. However a full and complete alignment is highly recommended at this point.

Good luck, 73 WDØGOF

WDØGOF 3/6/2014